



Mechanical SHORTSLEEVE™ Fittings For Steel Pipe

Size: 2-inch



T.D. Williamson

Bulletin No: 2110.002.02

Version: 01.2023

Supersedes: 2110.002.01 (02.2000)

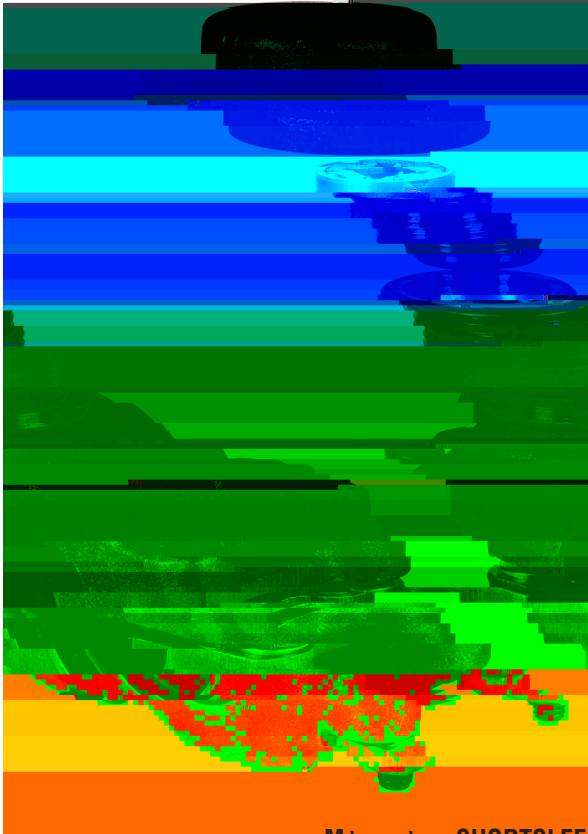

Mechanical SHORTSLEEVE™ Fittings

DESCRIPTION

Mechanical SHORTSLEEVE™ Fittings eliminate welding. They are designed for use on 2-3/8 (60 mm) OD steel pipe with the TDW SHORTSTOPP® Plugging Machine system.

FEATURES

Circumferential and longitudinal sealing elements provide a continuous seal around the pipe. Mechanical SHORTSLEEVE™ Fittings can also be used without plugging machines to install branch connections. The maximum recommended operating pressure is 175 psi (12 bar) @ 150°F (66°C). The maximum recommended operating temperature is 180°F (82°C) @ 165 psi (11 bar). When used with the SHORTSTOPP® 60 Plugging Machine, the maximum recommended plugging pressure is 60 psi (4 bar).



Plugging Machine

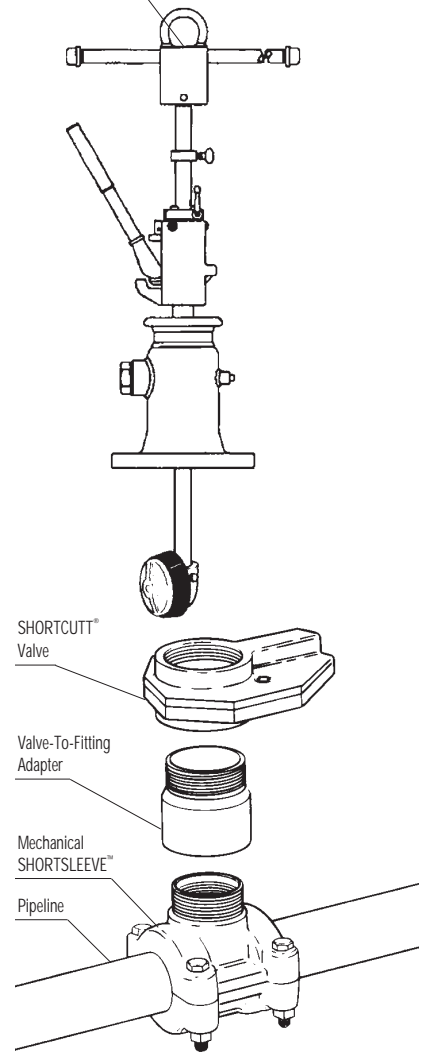

SHORTCUTT® Valve

Valve-To-Fitting Adapter

Mechanical SHORTSLEEVE™

Pipeline

